	FLAME ARRESTER 934-B-T 80(65)/3x0,2	REV 1.0
	INSTRUCTIONS FOR OPERATING AND MAINTENANCE	Page 1/5

For the flame arrester type 934-B-T/3x0,2 dimension sheet and pressure drop/volume flow diagram are available.

1. Use

The flame arrester type 934-B-T/3x0,2 complies with the standard EN ISO 16852:2016 "Flame Arresters-Performance requirements, test methods and limits for use".

The general suitability as a deflagration and short time-burning flame arrester when used with inflammable gas/air mixture and vapour/air mixture of inflammable liquids of the explosion group IIC (gap < 0,5 mm) had been verified by tests executed at the Institute for Safety Technology IBExU Freiberg. The results of it were confirmed by the issued EC prototype test certificate **IBExU20ATEX2054_X**

On principle, for all cases of use the placement conditions, especially the following limits for the operating pressure and temperature have to be considered:

- Permissible operating pressure: atmospheric (0,8bar (absolute) to 1,1bar (absolute))
- permissible operating temperature : -20°C to 60°C

For the case of short time burning on the flame arrester element the flame arrester is equipped with an integrated temperature sensing element (resistance thermometer). In the case of exceeding the operating temperature by ≥ 60 K a temporary unlimited stabilized burning on the flame arrester element shall be prevented by installing a resistance thermometer in connection with an automatic initiating of emergency functions (interruption or blanketing of the mixture flow).

On delivery of the devices the technical parameter of the flame arrester with stating the EC prototype test certificate number are documented in the works test certificate according to EN 10204. In the declaration of compliance it is referred to the accordance with the harmonized standard EN ISO 16852:2016.

The maintenance of the basic safety requirements according to directive 2014/34/EU has been confirmed.

2. Construction

The flame arrester 934-B-T/3x0,2 consists of a housing (1), in which a flame arrester element (3) is firmly clamped by means of studs (2) and spacer sleeves (5).

The flame arrester itself consists of a covering flange, a grid cage, a star and three metal foil elements. The foil elements have different directions of winding in its gaps. The gap width amounts to 0.2 mm. The metal foils are kept constant on a distance of 2 mm by a bracket and a washer. The welded-on nut on the housing flange is used to screw in a resistance thermometer (4).

For protection against effects of the weather the flame arrester is equipped with a sheet metal cover (6).

Created By:	DM	Date: 07.04.20	BS&B FlameSAF Limited, Limerick, Ireland
Approved By:	BM	Date: 07.04.20	

	FLAME ARRESTER 934-B-T 80(65)/3x0,2	REV 1.0
	INSTRUCTIONS FOR OPERATING AND MAINTENANCE	Page 2/5

3. Marking

The information for marking the flame arrester is arranged on the nameplate, the hazard sign and an additional hazard sign (page 5/5).

The following data are indicated:

Nameplate:

- name and address of the manufacturer
- type (including version number)
- serial number and year of production
- number of the certificate (EC prototype certificate-no.)
- number of relevant standard – ISO 16852
- specific mark for prevention of explosions in connection with the mark indicating the group of devices II, and the letter “G” (for areas where explosive gas, vapour, air mixtures are available)
- explosion group
- CE mark with the number of the indicated inspection authority, which act during production

Hazard sign:

- **Warning Flame arresters have installation and application limits**
Type designation in accordance with ISO 16852
- sign for type of flame arrester: **DEF** (deflagration)
- ratio L_w/D (distance to ignition source): --- (not applicable)
- burn rate „BC“: **b** (short time burning)
- burn time t_{BT} (only for „BC“ b): **1 min**
- explosion group: **IIC**
- operational temperature T_o : **60°C**
- maximum operational pressure p_o : **atm.** (atmospheric)

Warning note:

Note: This flame arrester is safe for short time burning!
Please refer to operating and maintenance instructions!

The flame arrester is marked on the outer border of the pipe socket as follows: BS&B - 3x0,2

The metal foil is marked at the outermost wound element, as follows:

- name of the manufacturer
- gap width
- material number
- direction of winding

Example: BS&B – 0,2 – 1.4571 – R

4. Installation

The arrangement and the installation of the flame arrester into the plant shall be done under observance of the rules applicable to the relevant range of use. Especially the instructions for accident prevention have to be observed.

A vertical installation position of the flame arrester has to be kept under any circumstances.

A minimum distance of outlet to external devices has to be adhered, to avoid reduction of volume flow resp. to avoid damage due to flame causing by short time burning.

This minimum distance depends on local circumstances and has to be specified by operator.

Flame arrester for continuous burning must not be equipped with heat insulation.

Created By:	DM	Date: 07.04.20	BS&B FlameSAF Limited, Limerick, Ireland
Approved By:	BM	Date: 07.04.20	

	FLAME ARRESTER 934-B-T 80(65)/3x0,2	REV 1.0
	INSTRUCTIONS FOR OPERATING AND MAINTENANCE	Page 3/5

Special attention must be paid to the resistance thermometer (4) for assembly or transport; it must be removed if necessary.

In the flanged version the flame arrester is equipped with a flanged connection PN16 – form C or ANSI 150 RF. When flanging, make sure that the sealing face is not damaged and that there are no foreign bodies or dirt between the flanges so that no gap to the atmosphere can occur.

In the threaded version the flame arrester is equipped with an internal pipe thread Rp or NPTF. The corresponding tapered male thread R or NPTF is recommended for the connecting pipe.

Parallel internal screw thread (flame arrester unit)	Rp (BSP) 2 1/2"
Tapered external thread (pipeline)	R 2 1/2"
Width across flats	SW 65

Tapered internal screw thread (flame arrester unit)	NPTF 2 1/2"
Tapered external thread (pipeline)	NPTF 2 1/2"
Width across flats	SW 65

When connecting the temperature sensor to the measuring system, the installation guidelines of the resistance thermometer manufacturer and the conditions for ensuring conformity must be observed. The connection between the resistance thermometer and the device for interrupting the mixture supply or an equivalent measure (triggering an emergency function) must be made in such a way that the dangerous state is eliminated within 30 s after the flame is detected by the resistance thermometer.

5. Maintenance

Maintenance includes a periodic visual inspection of the flame arrester unit, especially of the flame arrester elements with regard to contamination and condition. The time intervals for maintenance work shall depend on the operating conditions and the tendency of the individual media to become soiled and be determined by the operator.

Remove the sheet metal cover (6) by loosening the cap screws (7). Remove the resistance thermometer (4) and then remove the flame arrester (3) by loosening the spacer sleeves (5).

In case of minor contamination the flame arrester element shall be blown out with compressed air or superheated steam.

In case of major contamination a flushing with a cleaning agent can be carried out. After cleansing, all parts which had been wetted by a cleansing agent; must be blown dry.

The assembly of the flame arrester is done in reverse order to the disassembly above.

During the cleansing works no mechanical modifications may be done on the flame arrester element or on the housing parts of the flame arrester.

The flame arrester has to be replaced by a new one if:

- a fire occurred at the flame arrester element;
- loosening or distortions in the structure of the metal foil elements can be recognized;
- corrosion damages at the metal foil elements have been detected;
- in case of strongly contaminated metal foil elements, even after cleaning, a residual contamination of more than 30 % of the free flow area remained.

All works in connection with the replacement of metal foil elements in a flame arrester element shall be executed only by a trained and authorized skilled personnel.

Created By:	DM	Date: 07.04.20	BS&B FlameSAF Limited, Limerick, Ireland
Approved By:	BM	Date: 07.04.20	

	FLAME ARRESTER 934-B-T 80(65)/3x0,2 INSTRUCTIONS FOR OPERATING AND MAINTENANCE	REV 1.0
		Page 4/5

In case of replacement of structural units only original spare parts listed in the spare parts list may be installed to ensure the required safety.

6. Spare part list

Table : spare parts 934-B-T/2x0,7

Pos. No.	Pipe size	Designation	No.	Material	Order No.
1	80(65)	Flame arrester assembly 3x0,2	1	NSt	FET15334272
3	80(65)	Metal cover	1	NSt	FET994738000
8	25 - 80	Resistance thermometer	1	NSt	FET662044220

Material marks

St ... steel	NSt ... stainless steel
--------------	-------------------------

Created By:	DM	Date: 07.04.20	BS&B FlameSAF Limited, Limerick, Ireland
Approved By:	BM	Date: 07.04.20	



FLAME ARRESTER
934-B-T 80(65)/3x0,2
INSTRUCTIONS FOR OPERATING AND MAINTENANCE

REV 1.0

Page 5/5

Assembly Drawing 934-B-T/3x0,2

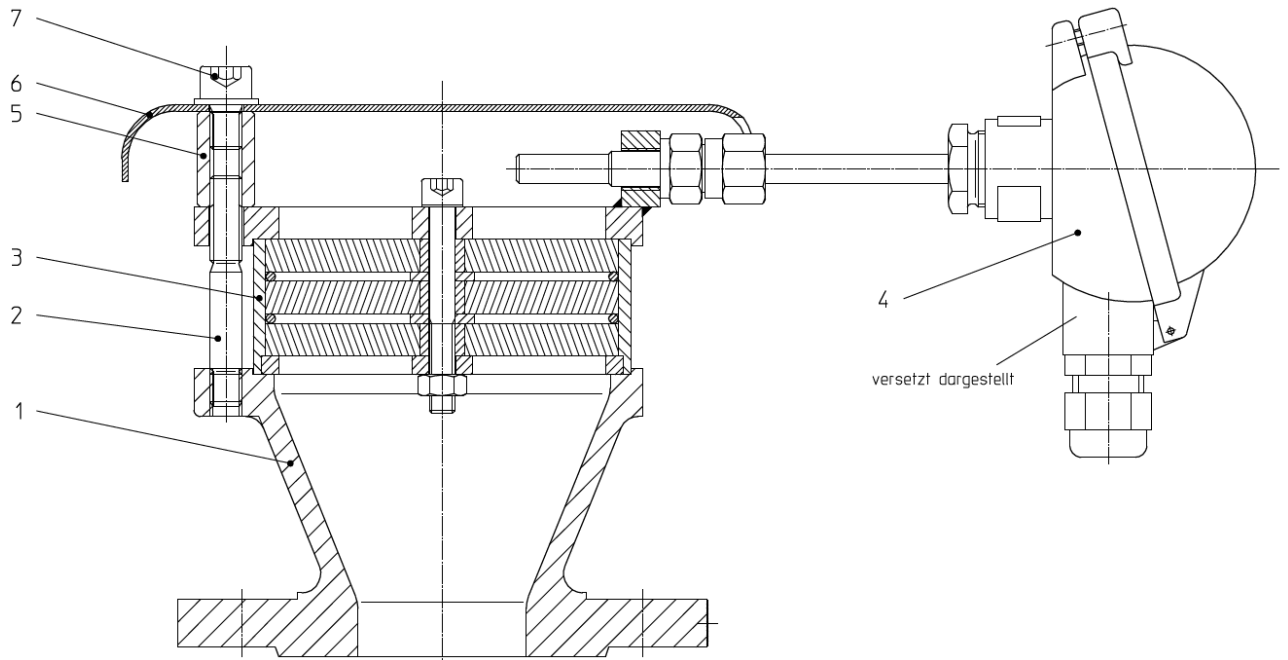

Nameplate

 BS&B FlameSaf Raheen Business Park Limerick, Ireland	Flame Arrester		- ISO 16852	
	Type	BS&B 934-B-T/80/3x0,2/ICP1T1		
	Cert-No			
Ser.-No	FS20xxxxxx-x xx			

Warning Label

DEF	$L_v/D =$	---	BC :	b	$t_{BT} =$	1 min
	Ex. G	IIC	$T_0 =$	60 °C	$p_0 =$	atm

Warning note

Note : This flame arrester is safe for short time burning !
 Please refer to operating and maintenance instructions !

Created By:	DM	Date:	07.04.20	BS&B FlameSAF Limited, Limerick, Ireland
Approved By:	BM	Date:	07.04.20	